

RoHS

受控

SPECIFICATION:

- Current Rating: 1.5A AC/DC
- Contact resistance: 20mΩ(Max).
- Insulation Resistance: 1000MΩ Min
- Withstanding Voltage: 500VAC(1Min)
- Operation Temperature: -40°C to +105°C
- Max Processing Temp: 230°C-260°C for 30-60 seconds
- Material:
- Insulator : Glass filled PA6T (UL94V-0), black
- Contacts: Brass

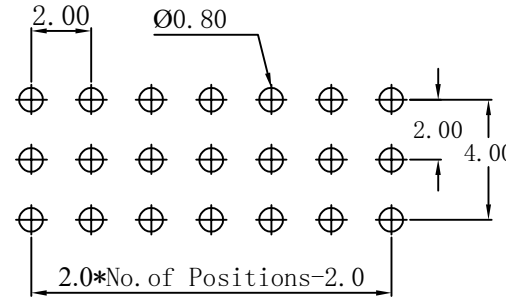
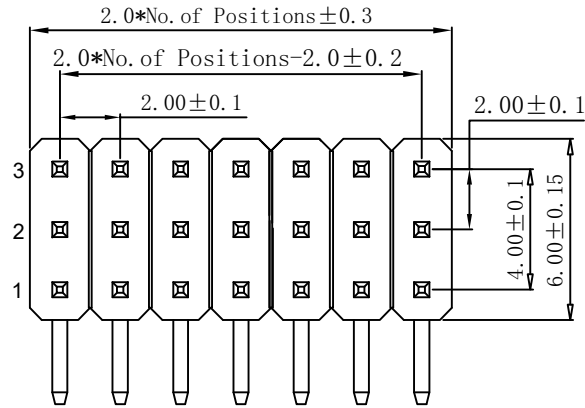

PCB LAYOUT

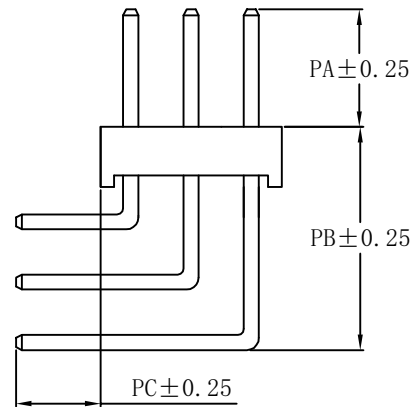
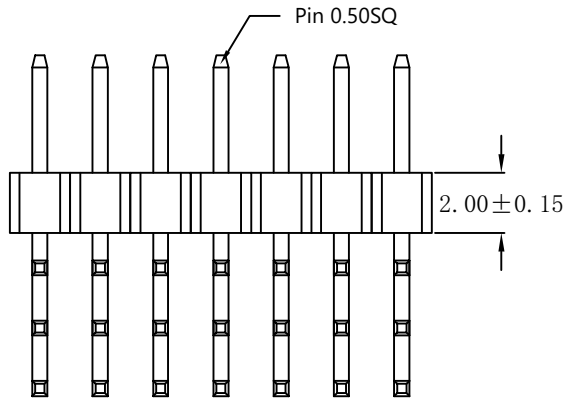

Ordering Information

PH200H200 RT- 3xx L1850 G A 0 301

Insulator height 200=2.00mm
 No. of Pins 320=3X20PIN
 1850=18.50mm
 Plating G=Gold Plated T=Tin Plated G2=Gold 2u" G10=Gold 10u"
 Material A=PA6T
 Package 0=PE Bag 1=Tube&Reel 2=Tube 3=Tray

Dimension antitheses list						
ITEM	PA	PB	PC	LS	LM	LL
Alternate	4.00	7.30	2.80	10.50	14.50	18.50

SCONDAR ELECTRONIC LTD
ENGINEER LIJU APPROVED

AO	2021.04.23	NEW			OPERATION	DRAW	Peng	2017.04.18	SCALE	-	 SCONDAR ELECTRONIC LIMITED	
					X.X	±0.35			UNIT	mm		
					X.XX	±0.25			SIZE	A4		
					X.XXX	±0.15			SHEET	1/1		
REV	DATE	MODIFICATION DESCRIPTION	CHANGE	APPROVE	Angle	± 3'			PROJ.	⊕	PART NO.	PH200H200RT-3xxL1850GA0301
					DIM	TOL					TITLE:	PH2.0 RT H2.0 PA4.0 PB7.30 PC2.8 LS10.5 LM14.5 LL18.50 Gold flash PA6T 3XXP Pin header