

RoHS

受控

**SPECIFICATION:**

- Current Rating: 1.5A AC/DC
- Contact resistance: 20mΩ(Max).
- Insulation Resistance: 1000MΩ Min
- Withstanding Voltage: 500VAC(1Min)
- Operation Temperature: -40°C to +105°C
- Max Processing Temp: 230°C-260°C for 30-60 seconds
- Material:
- Insulator : Glass filled PA6T (UL94V-0), black
- Contacts: Brass

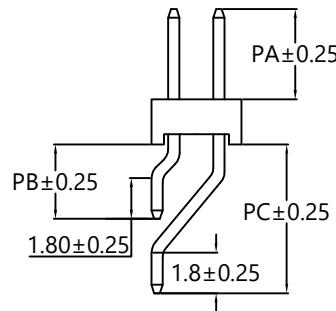
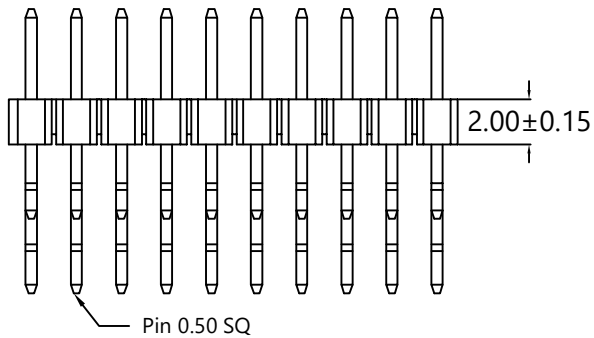
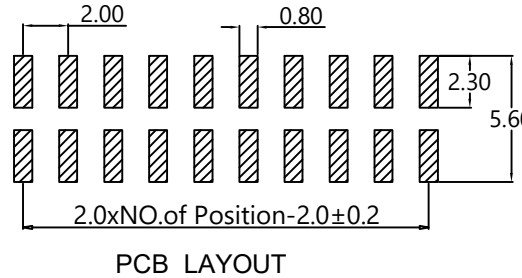
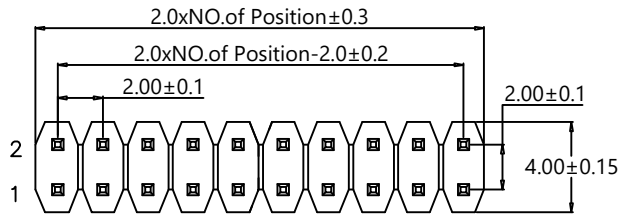

**Ordering Information**

PH200 H 200 RMT-2xx L1350 G A 1 301

Insulator height 200=2.00mm  
 No. of Pins 210=2X10P  
 Length L1350=13.50  
 Plating G=Gold Plated G2=Gold 2U" G3=Gold 3U" G10=Gold 10U" T=Tin Plated  
 Material A=PA6T  
 Package 0=PE Bag 1=Tape&Reel 2=Tube 3=Tray

**Dimension antitheses list**

ITEM	PA	PB	PC	LS	LL
Alternate	4.00	3.30	6.70	9.30	13.50

SCONDAR ELECTRONIC LTD  
ENGINEER LIU APPROVED

OPERATION	DRAW	2017.06.11
X.X ±0.35	DESIGN	
X.XX ±0.25		
X.XXX ±0.15	CHECK	2017.06.13
Angle ± 3'	APPROVE	
DIM TOL		

**SCONDAR ELECTRONIC LIMITED**

AO	2021.06.09	NEW																			
REV	DATE	MODIFICATION DESCRIPTION	CHANGE	APPROVE																	

PART NO.	PH200H200RMT-2xxL1350GA1301
PROJ.	TITLE: PH2.0H2.0 SMT WR LS 9.3 LL 13.5 PA4.0 PB3.3 PC6.7 Gold flash PA6T 2XXPIN header