

RoHS

受控

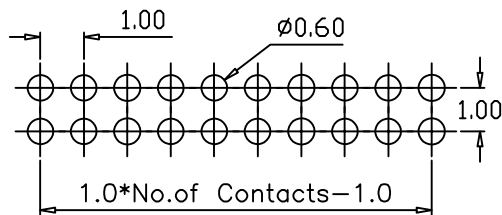

PCB LAYOUT

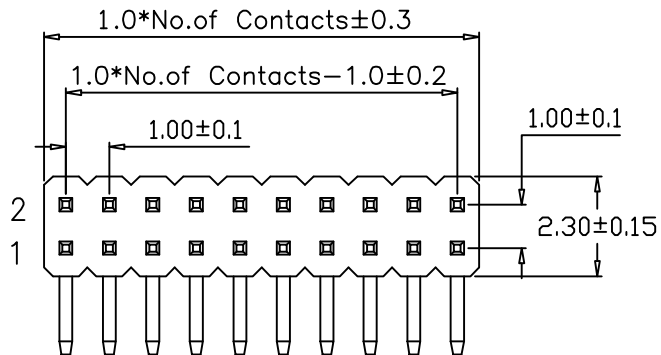
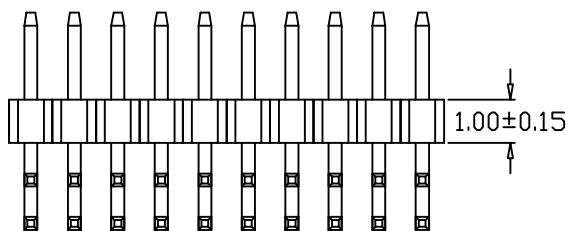

PIN 0.3SQ

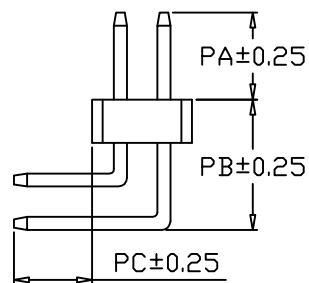

SPECIFICATION:

- Current Rating: 1A AC/DC
- Contact resistance: 20mΩ(Max).
- Insulation Resistance: 1000MΩ Min
- Withstanding Voltage: 500VAC(1Min)
- Operation Temperature: -40°C to +105°C
- Max Processing Temp: 230°C-260°C for 30°C-60°C seconds
- Material:
- Insulator : Glass filled PA6T (UL94V-0), black
- Contacts: Brass

Ordering Information

PH100H100 RT- 2xx G A 0 301

Insulator height 100-1.00mm
 No. of Pins 210-2X10PIN
 Plating G=Gold Plated T=Tin Plated G2=Gold 2u" G10=Gold 10u"
 Material A=PA6T
 Package 0=PE Bag 1=Tape&Reel 2=Tube 3=Tray

Dimension antitheses list

ITEM	PA	PB	PC	L短	L长
Alternate	1.80	3.00	1.80	6.20	8.20

SCONDAR ELECTRONIC LTD
 ENGINEER LIU APPROVED

REV	DATE	MODIFICATION DESCRIPTION	CHANGE	APPR	VE	PERATION	DRAW	Yang	2017.12.13	SCALE	-	 SCONDAR ELECTRONIC LIMITED	
AO	2021.7.3	NEW				X.X	±0.35			UNIT	mm		
						X.XX	±0.25			SIZE	A4		
						X.XXX	±0.15		2017.12.15	SHEET	1/1		PART N .
						Angle	± 3'			PR J.	☉	TITLE:	PH1.0 RT H1.0 PA1.8 PB3 PC1.8 L#8.2 Gold flash PA6T 2XXP Pin header