

RoHS

受控

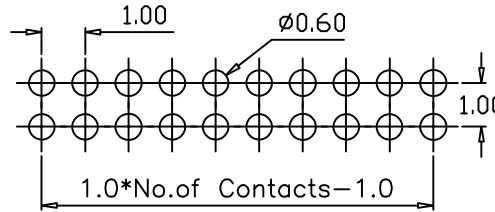
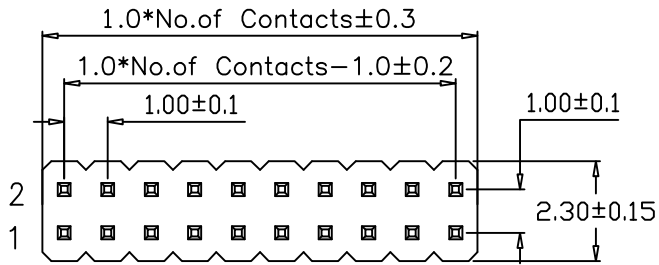

PCB LAYOUT

SPECIFICATION:

- Current Rating: 1A AC/DC
- Contact resistance: 20mΩ(Max).
- Insulation Resistance: 1000MΩ Min
- Withstanding Voltage: 500VAC(1Min)
- Operation Temperature: -40°C to +105°C
- Max Processing Temp: 230°C-260°C for 30°C-60°C seconds
- Material:
- Insulator : Glass filled PA6T (UL94V-0), black
- Contacts: Brass

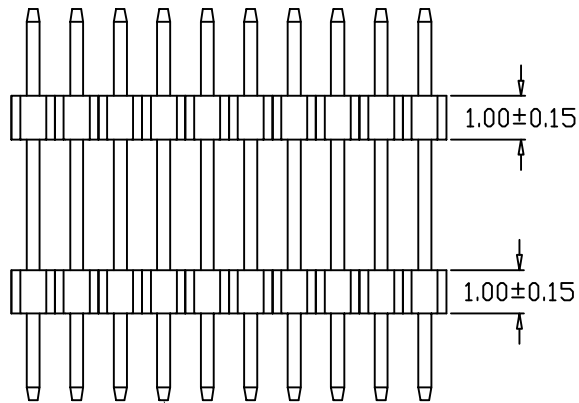

PIN 0.3SQ

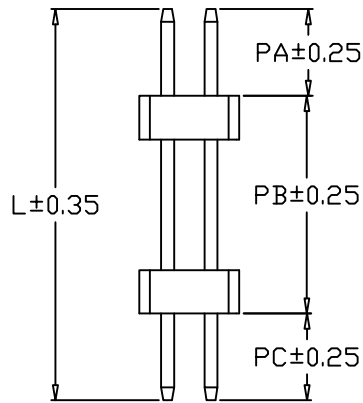

Ordering Information

PH100DH100 ST- 2xx G A 0 301

- Insulator height 100=1.00mm
- No. of Pins 210=2X10PIN
- Plating G=Gold Plated, T=Tin Plated, G2=Gold 2u", G10=Gold 10u"
- Material A=PA6T
- Package 0=PE Bag, 1=Tape&Reel, 2=Tube, 3=Tray

Dimension antitheses list

ITEM	PA	PB	PC	L
Alternate	2.00	5.00	2.00	9.00

SCONDAR ELECTRONIC LTD
ENGINEER LIU APPROVED

AO	2021.7.5	NEW			OPERATION	DRAW	Yang	2017.5.13	SCALE	-	<p>SCONDAR ELECTRONIC LIMITED</p>	
					X.X	±0.35			UNIT	mm		
					X.XX	±0.25			SIZE	A4		
					X.XXX	±0.15			SHEET	1/1	PART NO.	PH100DH100ST-2xxGA0301
REV	DATE	MODIFICATION DESCRIPTION	CHANGE	APPROVE	Angle	± 3'			PROJ.	⊕	TITLE:	PH1.0 ST DH1.0 PA2.0 PB5.0 PC2.0 L9.0 Gold flash PA6T 2XXP Pin Double header
					DIM	TOL	APPROVE					