

RoHS

受控

**SPECIFICATION:**

- Current Rating: 1A AC/DC
- Contact resistance: 20mΩ(Max).
- Insulation Resistance: 1000MΩ Min
- Withstanding Voltage: 500VAC(1Min)
- Operation Temperature: -40°C to +105°C
- Max Processing Temp: 230°C-260°C for 30°C-60°C seconds
- Material:
- Insulator : Glass filled PA6T (UL94V-0), black
- Contacts: Brass

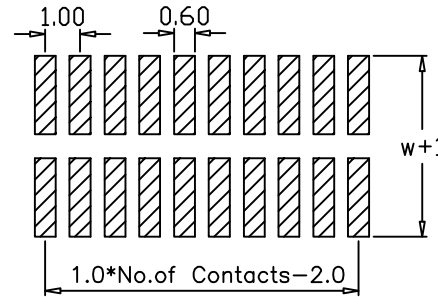
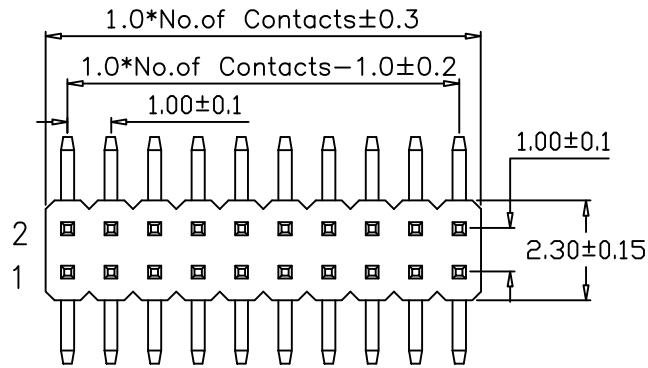

PCB LAYOUT

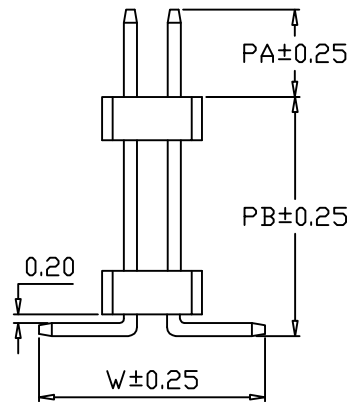
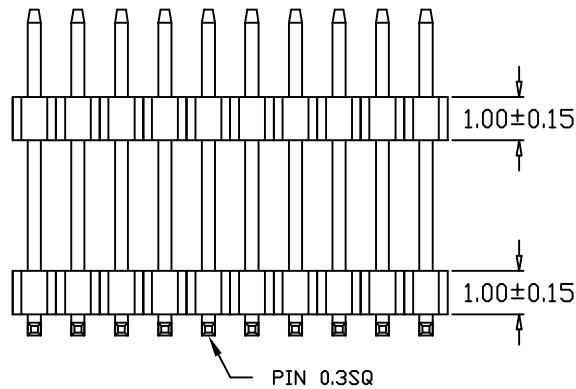

**Ordering Information**

PH100DH100 SMT - 2xx G A 1 301

Insulator height  
100-1.00mm

No. of Pins  
210-2X10PIN

Plating  
G=Gold Plated  
T=Tin Plated  
G2=Gold 2u"  
G10=Gold 10u"

Material  
A=PA6T

Package  
0=PE Bag  
1=Tube  
2=Tray  
3=Tray

**Dimension antitheses list**

ITEM	PA	PB	W	L
Alternate	2.00	5.00	5.20	8.70

SCONДАР ELECTRONIC LTD  
ENGINEER LIU APPROVED

OPERATION	DRAW	Yang	2017.04.05	SCALE	-
X.X ±0.35	DESIGN			UNIT	mm
X.XX ±0.25				SIZE	A4
X.XXX ±0.15	CHECK	Lisa	2017.04.08	SHEET	1/1
Angle ± 3'	APPROVE			PROJ.	☐
DIM TOL				TITLE:	PH100DH100SMT-2xxGA1301

**SCONДАР**  
SCONДАР ELECTRONIC LIMITED

AO	2021.7.04	NEW		
REV	DATE	MODIFICATION DESCRIPTION	CHANGE	APPROVE

PH1.0 SMT H1.0 PA2.0 PB5.0 W5.2 L8.70  
Gold flash PA6T 2XXP Pin Double header