

RoHS

受控

**SPECIFICATION:**

- Current Rating: 3Amps
  - Insulation Resistance: 1000MΩ Min
  - Contact Resistance: 20mΩ Max
  - Withstanding Voltage: 500VAC(1Min)
  - Max Processing Temp: 230°-260° for 30-60s
  - Operation Temperature: -40°C to +105°C
- Material:
- Insulator (Housing): PA6T (UL94V-0)
  - Contacts: Brass
  - Contact Plated: Gold Plated or Tin Plated

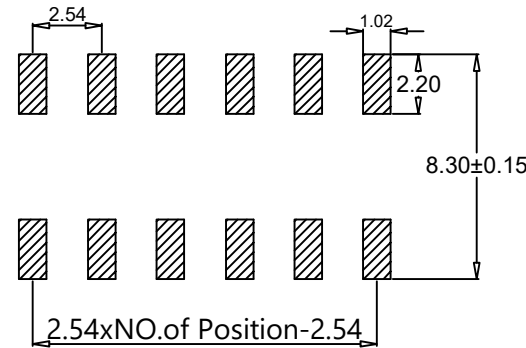
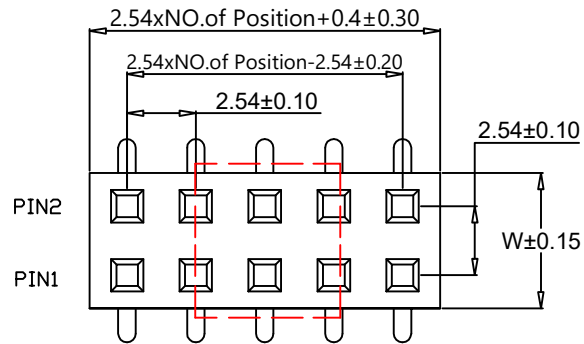

**PCB LAYOUT**

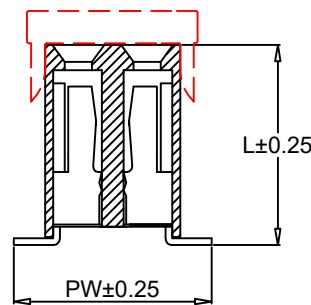
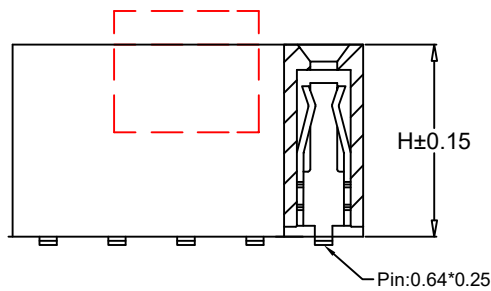

**Ordering Information**

FH254Hxxx SMT - 2xx G A 1 301 U

Insulator height: 350=3.50mm, 500=5.00mm, 710=7.10mm, 750=7.50mm, 850=8.50mm  
 No. of Pins: 220=2X20PIN  
 Plating: G=Gold Plated  
 Material: A=PA6T  
 Package: 0=PE Bag, 1=Tape&Reel, 2=Tube, 3=Tray  
 Contact: Y=Y shape, U=U shape

H	W	PW	L	PIN
3.50	5.00	7.20	3.90	0.55*0.25
5.00	5.00	6.70	5.25	0.60*0.25
7.10	5.00	7.30	7.40	0.60*0.25
7.50	5.00	7.50	7.90	0.60*0.25
8.50	5.00	7.30	8.90	0.60*0.25

SCONDAR ELECTRONIC LTD  
ENGINEER LIU APPROVED

AO	2021.05.15	NEW			OPERATION	DRAW	LYao	2017.04.06	SCALE	-	 SCONDAR ELECTRONIC LIMITED	
					X.X	±0.35			UNIT	mm		
					X.XX	±0.25			SIZE	A4		
					X.XXX	±0.15		2017.04.07	SHEET	1/1		
REV	DATE	MODIFICATION DESCRIPTION	CHANGE	APPROVE	Angle	± 3'			PROJ.	⊕	PART NO.	FH254HxxxSMT-2xxGA1301U
					DIM	TOL	APPROVE				TITLE:	FH2.54 W=5.0 2XXPin SMT Female Header