

RoHS

受控

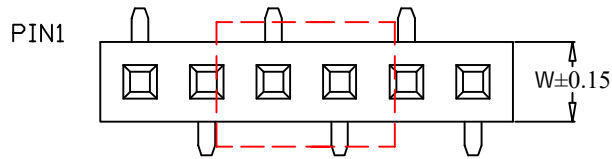

TYPE A

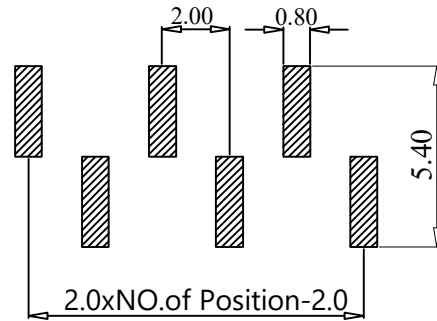

P.C.B Layout  
TYPE A

SPECIFICATION:

- Current Rating: 1.5Amps
- Insulation Resistance: 1000MΩ Min
- Contact Resistance: 20mΩ Max
- Withstanding Voltage: 500VAC(1Min)
- Max Processing Temp: 230°-260° for 30-60s
- Operation Temperature: -40°C to +105°C

Material:

- Insulator (Housing): PA6T (UL94V-0)
- Black Contacts: Brass

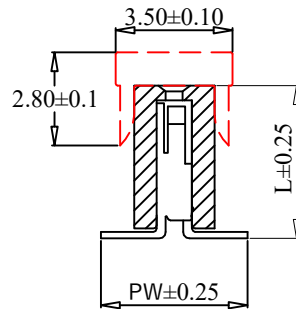
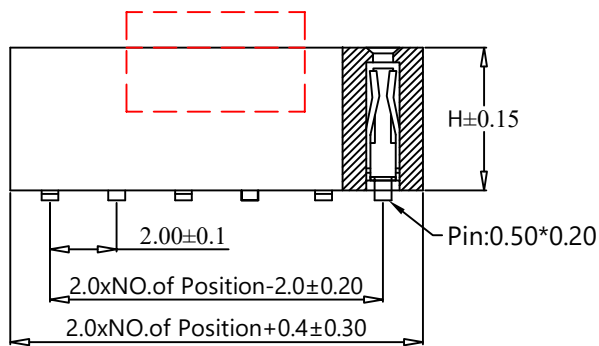

Ordering Information

FH200Hxxx SMT-1xx G A 1 301 A

Insulator height: 220=2.20mm, 430=4.30mm, 460=4.60mm  
 No. of Pins: 120=1x20PIN  
 Plating: G=Gold Plated, T=Tin Plated, G2=Gold 2u", G10=Gold 10u"  
 Material: A=PA6T  
 Package: 0=PE Bag, 1=Tape&Reel, 2=Tube, 3=Tray  
 A=PCB type A, B=PCB type B

H	W	PW	L
2.20	2.40	4.30	2.50
4.30	2.40	4.40	4.60
4.60	2.40	4.40	4.90

SCONDAR ELECTRONIC LTD  
ENGINEER LIU APPROVED

AO	2021.05.25	NEW			OPERATION	DRAW	LYao	2016.04.12	SCALE	-	 SCONDAR ELECTRONIC LIMITED	
					X.X	±0.35			UNIT	mm		
					X.XX	±0.25			SIZE	A4		
					X.XXX	±0.15		2016.04.15	SHEET	1/1		
REV	DATE	MODIFICATION DESCRIPTION	CHANGE	APPROVE	Angle	± 3'			PROJ.	⊕	PART NO.	FH200H430SMT-1xxGA1301A
					DIM	TOL	APPROVE				TITLE:	FH2.0 H4.3 SMT Gold flash PA6T 1xxP Female header PCB layout type A