

RoHS

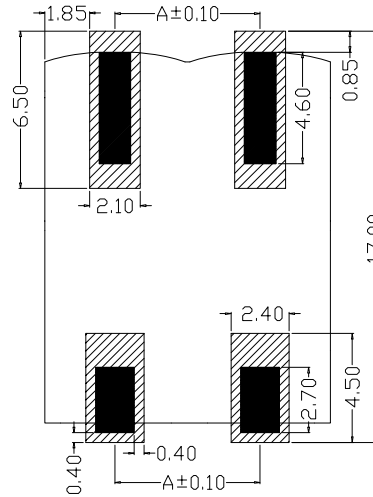
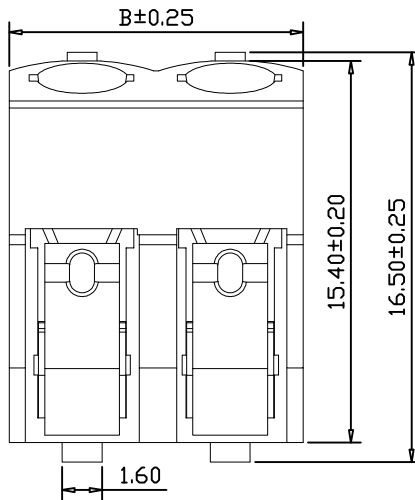
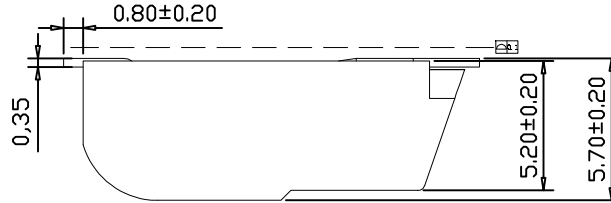
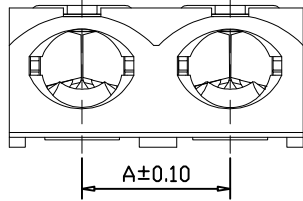
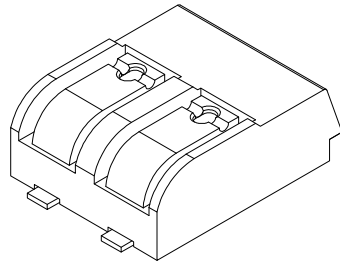

PCB LAYOUT

SPECIFICATIONS

- 1、Current Rating: 10A AC, DC
- 2、Voltage Rating: 300V AC, DC
- 3、Temperatuer Range: -40°C~+125°C
- 4、Contact Resistance: 20mΩ Max
- 5、Insulation Resistance: 1000MΩ Min
- 6、Withstanding Voltang: 1500V AC/minute
- 7、Material:Wafer LCP,UL94V-0  
PIN Phosphoric bronzes Tin-plated
- 8、Can connect wire:AWG#16-20#

Ordering Information

SCT2061WRS - 60 -XX F 1 182

Series NO. Pitch=6.0 No.of Pins See Table Material F=LCP Package  
0=PE Bag  
1=tape &reel  
2=tube  
3=tray

Dimensions		Part NO	PIN
A	B		
/	5.80	SCT2061WRS60-01F1182	1
6.00	11.80	SCT2061WRS60-02F1182	2
12.00	17.80	SCT2061WRS60-03F1182	3

SCONDAR ELECTRONIC LIMITED  
ENGINEER LIU APPROVED

DRAW	Zhong	2020.08.02	SCALE	-	 SCONDAR ELECTRONIC LIMITED
DESIGN			UNIT	mm	
CHECK	Lisa	2020.08.02	SIZE	A4	
APPROVE	Allen	2020.08.02	SHEET	1/1	PART NO. SCT2061WRS60-XXF1182
			PROJ.	☯	TITLE:
					Terminal pitch6.0XL16.5mm SMT WR xXP BE LCP-V0 phosphor Bronze Tin(Sn) plated 16-20AWG