

RoHS

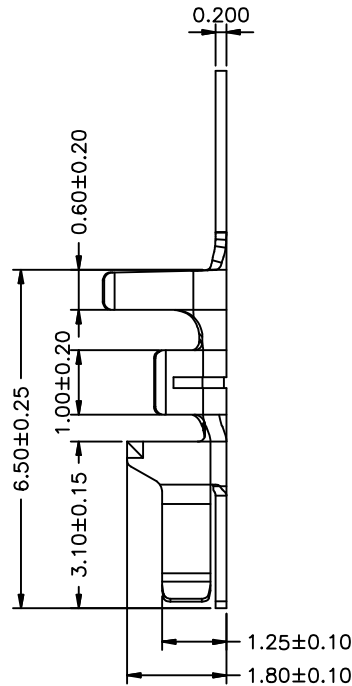
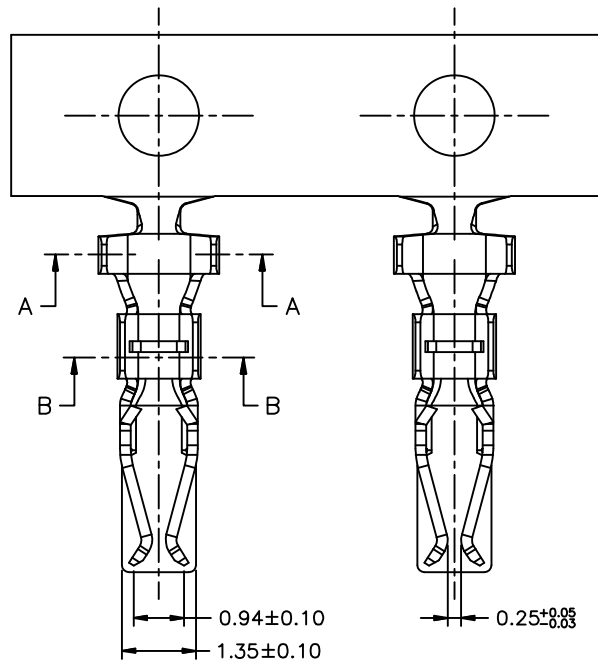

Specification:

- Current Rating: 2A AC/DC
- Voltage Rating: 125V AC/DC
- Insulation Resistance: 800MΩ(Min)
- Contact resistance: 20mΩ(Max).
- Withstanding Voltage: 500VAC(Min)
- Operation Temperature: -25°C to +85°C

Material:

- Wire Range: 22AWG~30AWG
- Insulation O.D: 1.45mm Max
- Material: Phosphor Bronze, T=0.20mm
- Finish: Tin Plated
- Q'TY: 10000Pcs/Reel

Ordering Information

SCT2011T P S 107

Material:
P=Phosphor Bronze S=Tin Plated

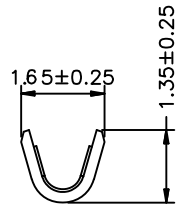
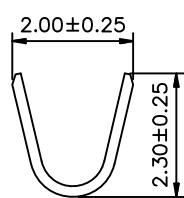

SECTION:A-A

SECTION:B-B

东莞市晟凯达电子科技有限公司
工程专用章

受控

					OPERATION	DRAW	Peng	2021.07.12	SCALE	-	 SCONDAR ELECTRONIC LIMITED	
					X.X ±0.35	DESIGN			UNIT	mm		
					X.XX ±0.25		CHECK	Lisa	2021.07.12	SIZE		A4
					X.XXX ±0.15	APPROVE	Allen	2021.07.12	SHEET	1/1		PART NO.
A1	2021.07.12	Changed from SCT2011TP to SCT2011TPS107			Angle				PROJ.	⌀	TITLE:	DF11 2.0mm Terminal
AO	2015.03.03	NEW			DIM	TOL						
REV	DATE	MODIFICATION DESCRIPTION		CHANGE	APPROVE							