

RoHS

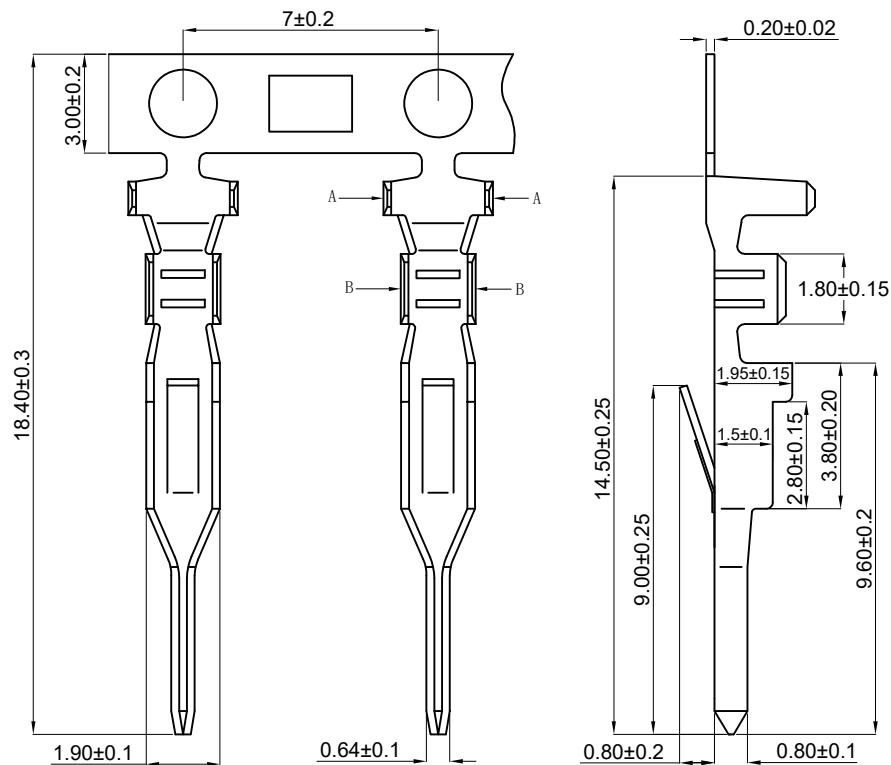

TECHNICAL PARAMETERS:
 Rated Current: 3A AC/DC
 Voltage Rated: 250V AC/DC
 Withstand voltage: 1000V AC/minute
 Insulation resistance: 1000MΩ min
 Contact resistance: 20mΩ(Max)
 Operating temperature: -25°C ~ +85°C
 Material
 Applicable wires: AWG28-22#
 Material: Phosphor Bronze
 Finish: Tin Plated

Ordering Information

SCT2521 MT P S 169

Material
 P=Phosphor bronze
 Contact Plating
 G=Gold Plated
 S=Tin Plated

SCONDAR ELECTRONIC, LTD
 ENGINEER XJ2412

OPERATION	DRAW	YaoQ	2016.06.15
X.X ±0.35	DESIGN	Lyao	2016.06.16
X.XX ±0.25	CHECK	Lisa	2016.06.18
X.XXX ±0.15	APPROVE		
Angle ±3°			
DIM TOL			

SCONDAR
 SCONDAR ELECTRONIC LIMITED

SCALE	—
UNIT	mm
SIZE	A4
SHEET	1/1
PART NO.	SCT2521MTPS169
TITLE:	25048HS 2.50mm Phosphor bronze Tin Plated Male Terminal 22-28AWG MPQ=8KPCS/Reel

AO	2016.06.18	NEW	—	—
REV	DATE	MODIFICATION DESCRIPTION	CHANGE	APPROVE