

RoHS

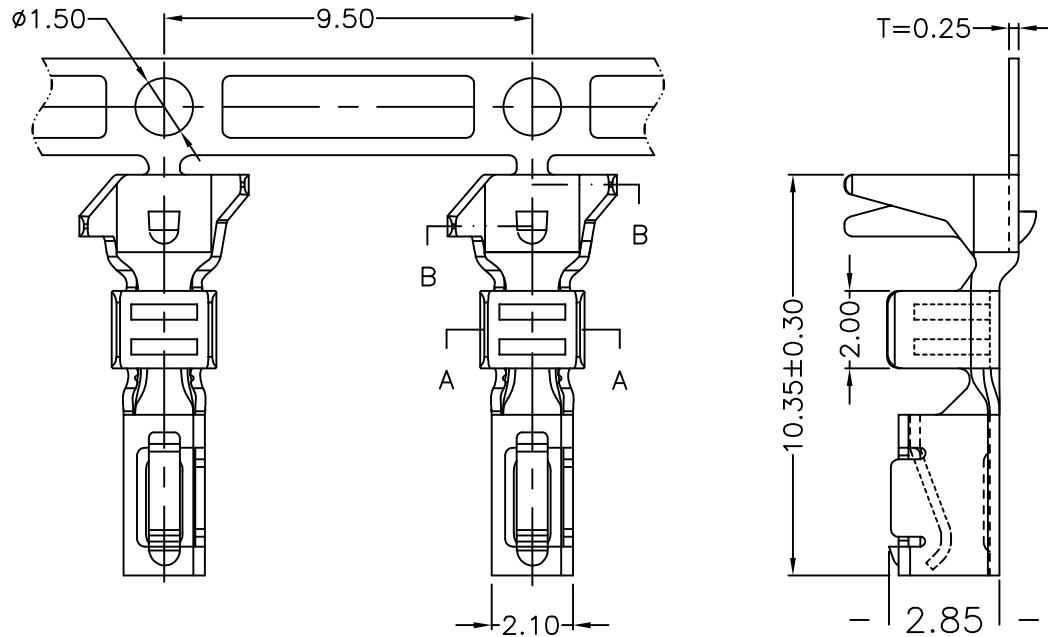

Specification:

- Current Rating: 15A AC/DC
- Voltage Rating: 600V AC/DC
- Insulation Resistance: 1000M $\Omega$  Min
- Withstanding Voltage: 1500VAC(1Min)
- Contact resistance: 10m $\Omega$ (Max).
- Operation Temperature: -55°C to +80°C

Material:

- Material: Phosphor Bronze
- Finish: Tin Plated
- Applicable Wires: 20AWG~22AWG

Ordering Information

SCT3964 TL P S 173

Material  
P=Phosphor Bronze

Contact Plated  
S=Tin Flash

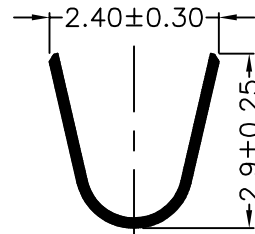
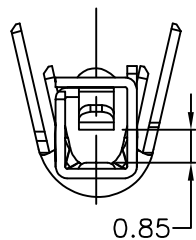

SECTION B-B

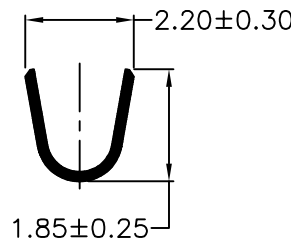

SECTION A-A

Specification				
Poles	16AWG	18AWG	20AWG	22AWG
1	15A	13A	11A	9A
2	14A	12A	10A	8A
3	12A	10A	8A	7A
4	10A	8A	7A	6A
5	10A	8A	7A	6A
6	10A	8A	7A	6A

SCONDAR ELECTRONIC, LTD  
ENGINEER 20241014

OPERATION	DRAW	Xiong	2022.07.06	SCALE	-
X.X ±0.35	DESIGN			UNIT	mm
X.XX ±0.25	CHECK	Lisa	2022.07.08	SIZE	A4
X.XXX ±0.15	APPROVE			SHEET	1/1
Angle ± 3'				PROJ.	☯
DIM TOL				TITLE:	



SCONDAR ELECTRONIC LIMITED

REV	DATE	MODIFICATION DESCRIPTION	CHANGE	APPROVE
A0	2022.07.06	NEW		

PART NO.	SCT3964TLPS173
TITLE:	DF63 3.96mm Phosphor Bronze Tin Plated Low foot Terminal 20-22AWG MPQ=0.4Kpcs/Reel