

RoHS

Recommended P.C.B Layout  
General Tolerance±0.05

Specification:

- Current Rating: 7A AC/DC
- Voltage Rating: 250V AC/DC
- Insulation Resistance: 1000MΩ(Min)
- Contact resistance: 20mΩ(Max).
- Withstanding Voltage: 1500VAC(Min)
- Operation Temperature: -25°C to +85°C

Material:

- Insulator Material: Nylon 66(UL94V-2)
- Contact Material: Brass
- Finish: Tin Plated
- Color: Nature

Ordering Information

SCT3960WV - xx C 0 NA 102

No.of Pins  
See Table  
Material  
C=PA66 V2  
Package  
0=PE Bag  
Color  
NA=Nature

9	31.68	35.64	17	63.36	67.32			
8	27.72	31.68	16	59.40	63.36			
7	23.76	27.72	15	55.44	59.40			
6	19.80	23.76	14	51.48	55.44			
5	15.84	19.80	13	47.52	51.48			
4	11.88	15.84	12	43.56	47.52	20	75.24	79.20
3	7.92	11.88	11	39.60	43.56	19	71.28	75.24
2	3.96	7.92	10	35.64	39.60	18	67.32	71.28
Poles	A B Dimensions		Poles	A B Dimensions		Poles A B Dimensions		

东莞市晟凯达电子科技有限公司  
工程专用章

受控

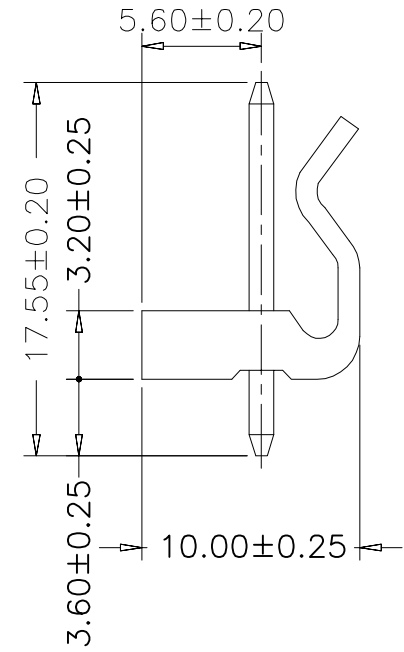
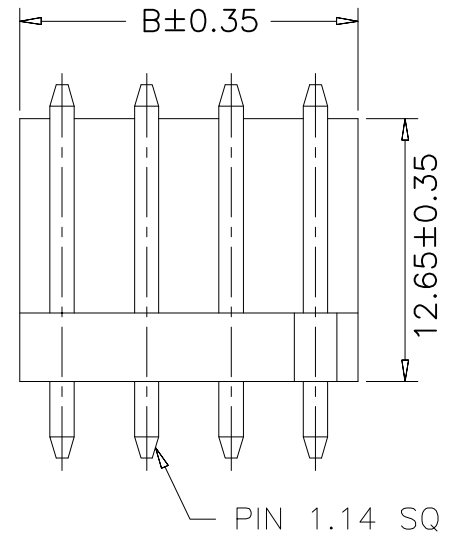
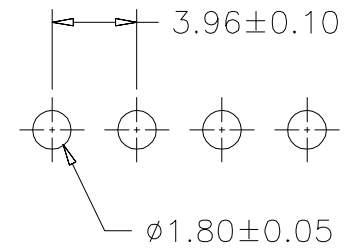
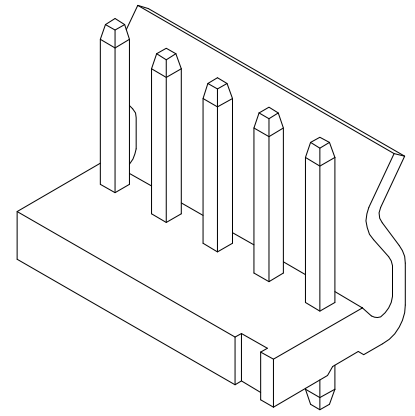
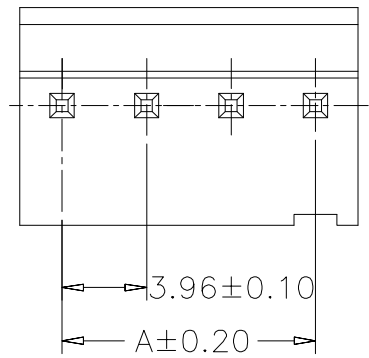

					OPERATION	DRAW	Peng	2021.07.10	SCALE	-	 SCONDAR ELECTRONIC LIMITED	
					X.X	±0.35			UNIT	mm		
A1	2021.07.10	Changed from SCT3960WV--xxP to SCT3960WV--xxCONA102			X.XX	±0.25			SIZE	A4		
A0	2020.03.03	NEW			X.XXX	±0.15			SHEET	1/1		
REV	DATE	MODIFICATION DESCRIPTION		CHANGE	APPROVE	Angle DIM	± 3' TOL	APPROVE	Allen	2021.07.10	PART NO.	SCT3960WV--xxCONA102
									PROJ.	MX3.96 180° Wafer	TITLE:	