

RoHS

东莞市赛凯达电子科技有限公司
工程专用章

Recommended P.C.B Layout
General Tolerance±0.05

Specification:

- Current Rating: 5A AC/DC
- Voltage Rating: 250V AC/DC
- Insulation Resistance: 1000MΩ Min
- Withstanding Voltage: 1500VAC Min
- Contact resistance: 20mΩ(Max).
- Operation Temperature: -25°C to +85°C

Material:

- Insulator (Housing): Nylon 66 (UL94V-2)
- Contacts: Brass
- Solder: Tin Plated
- Color: Black

受控

Ordering Information

SCT3001WV - ** B 0 BK 108

No. of Pins See Table
Insulation B=PA66
Package 0=PE Bag
Color BK=Black

10	27.00	33.65			
9	24.00	30.65			
8	21.00	27.65			
7	18.00	24.65			
6	15.00	21.65			
5	12.00	18.65			
4	9.00	15.65			
3	6.00	12.65	12	33.00	39.65
2	3.00	9.65	11	30.00	36.65
Poles	A		Poles	B	
	Dimensions			Dimensions	

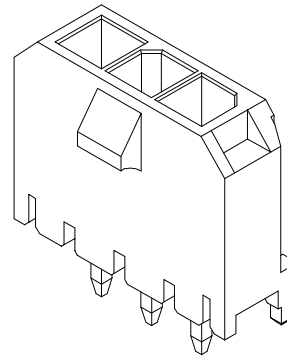
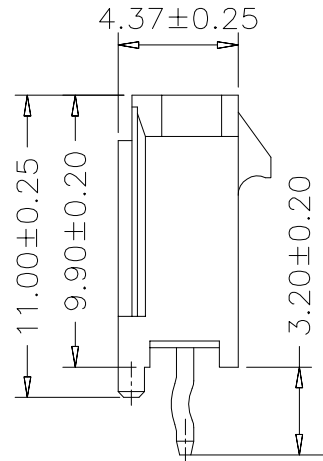
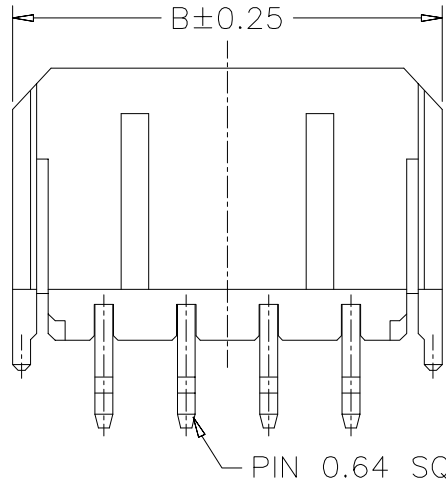
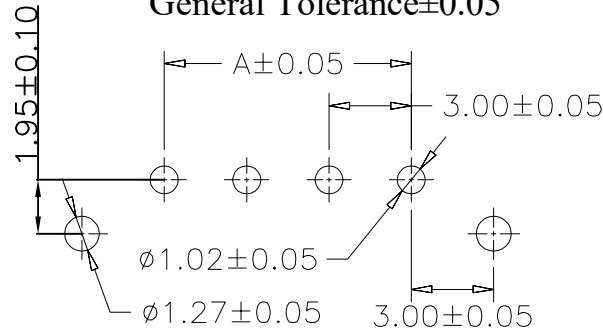
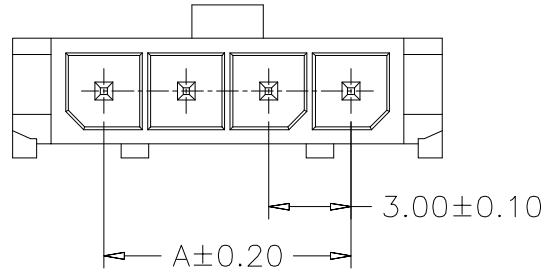

REV	DATE	MODIFICATION DESCRIPTION	CHANGE	APPROVE	OPERATION	DRAW	Yang	2022.06.20	SCALE	-	 SCONДАР ELECTRONIC LIMITED	
A1	2021.07.10	Changed from SCT3001WR-xxP to SCT3001WR-xxB0BK108			X.X	±0.35			UNIT	mm		
A0	2019.10.15	NEW			X.XX	±0.25			SIZE	A4		
					X.XXX	±0.15	Lisa	2022.06.20	SHEET	1/1		
					Angle	± 3'			PROJ.	1/1	PART NO.	SCT3001WV-xxB0BK108
					DIM	TOL					TITLE:	MX3.0 180° Wafer Connector