

RoHS

Specification:

- Current Rating: 3A AC/DC
- Voltage Rating: 125V AC/DC
- Insulation Resistance: 1000MΩ Min
- Withstanding Voltage: 500VAC(1Min)
- Contact resistance: 10mΩ(Max).
- After environmental testing: 20mΩ(Max).
- Operation Temperature: -40°C to +105°C

Material:

- Insulator (Housing): PBT (UL94V-0)
- Color: Natural

Ordering Information

SCT2018H - xx D NA 151

No.of Pins
See Table

Insulation
D=PBT

Color
NA=Natural

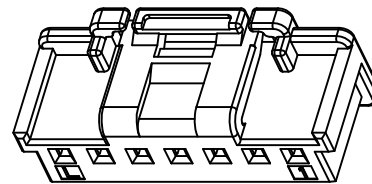
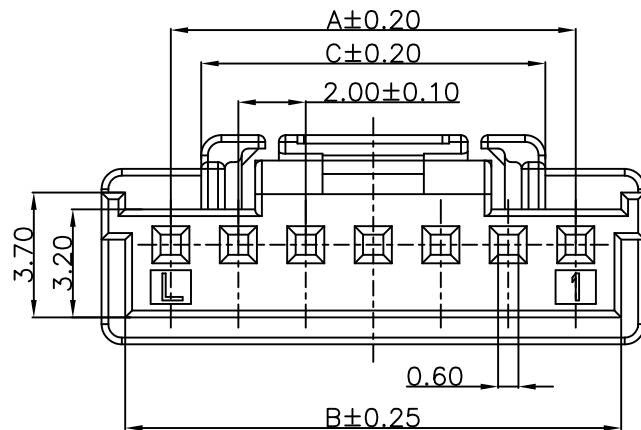
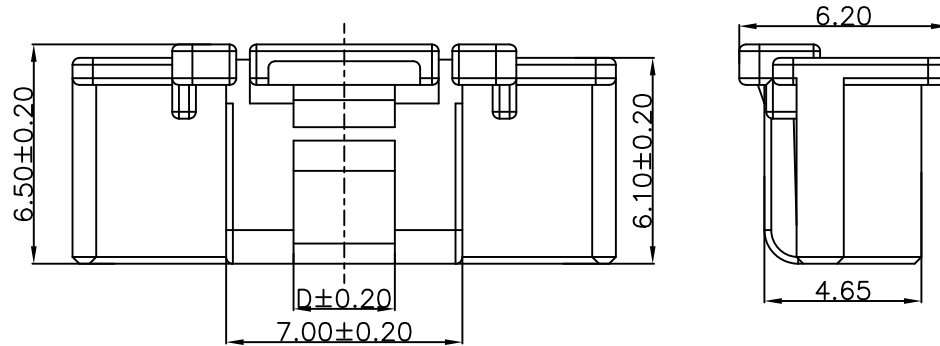

10	18.00	20.70	10.20	3.00						
9	16.00	18.70								
8	14.00	16.70								
7	12.00	14.70								
6	10.00	12.70					15	28.00	30.70	10.20
5	8.00	10.70			14	26.00	28.70			
4	6.00	8.70	10.10		13	24.00	26.70			
3	4.00	6.70	8.10	2.20	12	22.00	24.70			
2	2.00	4.70	8.00	2.00	11	20.00	22.70			
Poles	A	B	C	D	Poles	A	B	C	D	
	Dimensions					Dimensions				

						OPERATION	DRAW	Peng	2021.03.15	SCALE	-	 SCONDAR ELECTRONIC LIMITED	
						X.X ±0.35	DESIGN			UNIT	mm		
						X.XX ±0.25				SIZE	A4		
						X.XXX ±0.15	CHECK	Lisa	2021.03.15	SHEET	1/1		PART NO.
REV	DATE	MODIFICATION DESCRIPTION			CHANGE	APPROVE	APPROVE	Allen	2021.03.15	PROJ.		TITLE:	2.00mm Pitch Housing Connector