

RoHS

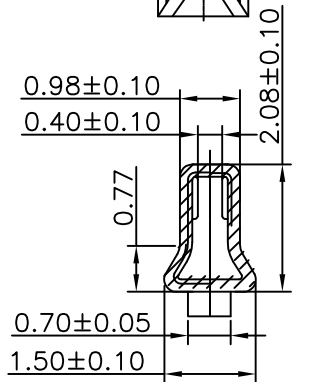

SECTION:C-C

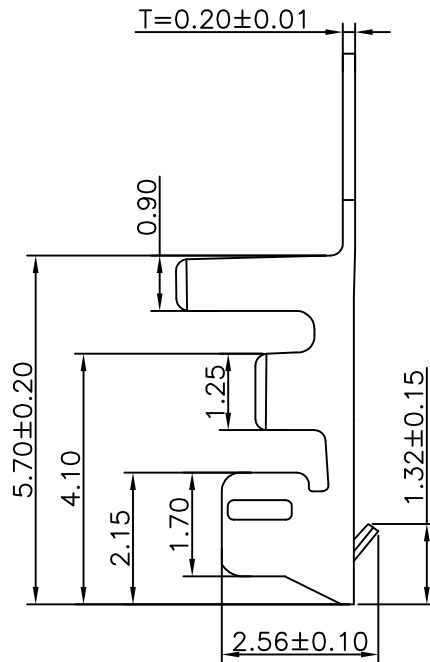
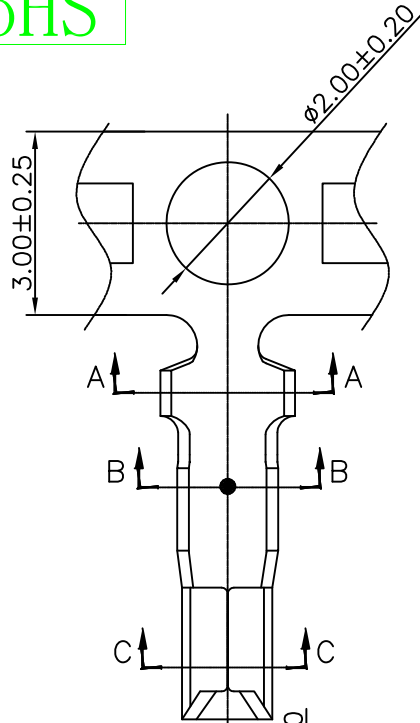
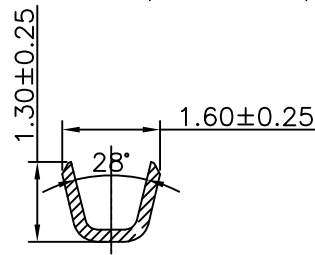

SECTION:B-B

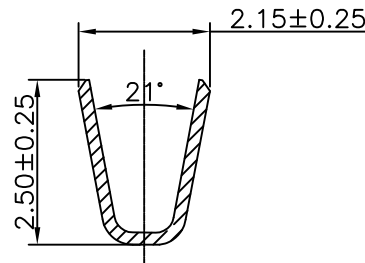

SECTION:A-A

Specification:

- Current Rating: 1A AC/DC
- Voltage Rating: 150V AC/DC
- Insulation Resistance: 500MΩ(Min)
- Contact resistance: 30mΩ(Max).
- Withstanding Voltage: 500VAC(Min)
- Operation Temperature: -35°C to +85°C

Material:



- Wire Range:24AWG~28AWG
- Insulation O.D: 1.4mm Max
- Material: Phosphor Bronze ,T=0.20mm
- Finish: Tin Plated/Gold Plated

Ordering Information

SCT2001T P S 105

Material:
P=Phosphor Bronze

Contact Plated
S=Tin Plated
G=Gold Plated

					OPERATION	DRAW	Peng	2021.07.12	SCALE	-	 SCONDAR ELECTRONIC LIMITED		
					X.X ±0.35	DESIGN			UNIT	mm			
					X.XX ±0.25	CHECK	Lisa	2021.07.12	SIZE	A4			
A1	2021.07.12	Changed from SCT2001TP to SCT2001TPS105			X.XXX ±0.15	CHECK			SHEET	1/1	PART NO.	SCT2001TPS105	
AO	2021.03.03	NEW			Angle ± 3'	APPROVE	Allen	2021.07.12	PROJ.		TITLE:	PH 2.00mm Terminal	
REV	DATE	MODIFICATION DESCRIPTION	CHANGE	APPROVE	DIM TOL								