

RoHS

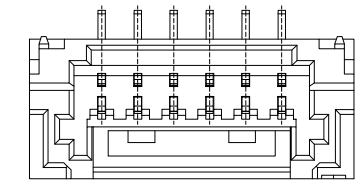

6-15P

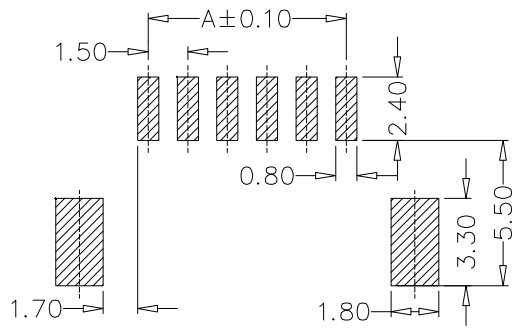
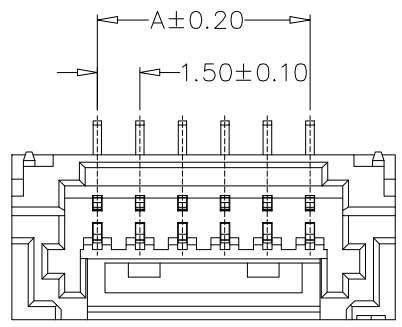
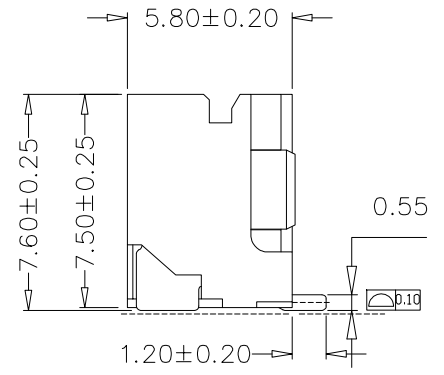
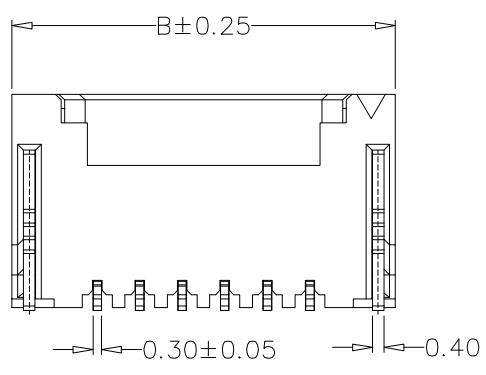
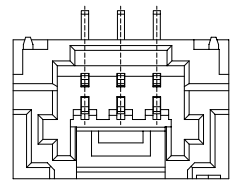

2-5P

Specification:  
 -Current Rating: 2A AC/DC  
 -Voltage Rating: 100V AC/DC  
 -Insulation Resistance: 100MΩ Min  
 -Withstanding Voltage: 500VAC(1Min)  
 -Contact resistance: 20mΩ(Max).  
 -Operation Temperature: -25°C to +85°C  
 Material:  
 -Insulator (Housing): LCP (UL94V-0)  
 -Color: Beige  
 -PIN Material: Phosphor Bronze  
 -Solder tab: Brass  
 -Finish: Tin Plated

Ordering Information

SCT1506WVS - xx F 1 BE 182  
 No. of Pins See Table    Insulation F=LCP    Package I=Tape&Reel    Color BE=Beige

21.00	27.00	SCT1506WVS-15F1BE182	15
19.50	25.50	SCT1506WVS-14F1BE182	14
18.00	24.00	SCT1506WVS-13F1BE182	13
16.50	22.50	SCT1506WVS-12F1BE182	12
15.00	21.00	SCT1506WVS-11F1BE182	11
13.50	19.50	SCT1506WVS-10F1BE182	10
12.00	18.00	SCT1506WVS-09F1BE182	9
10.50	16.50	SCT1506WVS-08F1BE182	8
9.00	15.00	SCT1506WVS-07F1BE182	7
7.50	13.50	SCT1506WVS-06F1BE182	6
6.00	12.00	SCT1506WVS-05F1BE182	5
4.50	10.50	SCT1506WVS-04F1BE182	4
3.00	9.00	SCT1506WVS-03F1BE182	3
1.50	7.50	SCT1506WVS-02F1BE182	2
A	B	Part NO	PIN
Dimensions			

SCONDAR ELECTRONIC LIMITED  
 ENGINEER LIU APPROVED

					OPERATION	DRAW	Zhong	2020.11.15	SCALE	—	 SCONDAR ELECTRONIC LIMITED	
					X.X	±0.30			UNIT	mm		
					X.XX	±0.20			SIZE	A4		
A0		NEW			X.XXX	±0.10	Check	Lisa	2020.11.15	SHEET		1/1
REV	DATE	MODIFICATION DESCRIPTION	CHANGE	APPROVE	Angle	±3°	APPROVE		PROJ.	◆	Part No.	SCT1506WVS-xxF1BE182
					DIM	TOL			◆	TITLE:		ZE1.5mm LCP V0 Beige SMT WV Socket