

RoHS

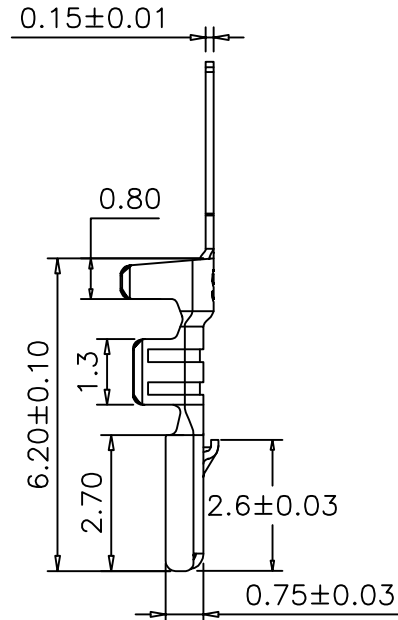
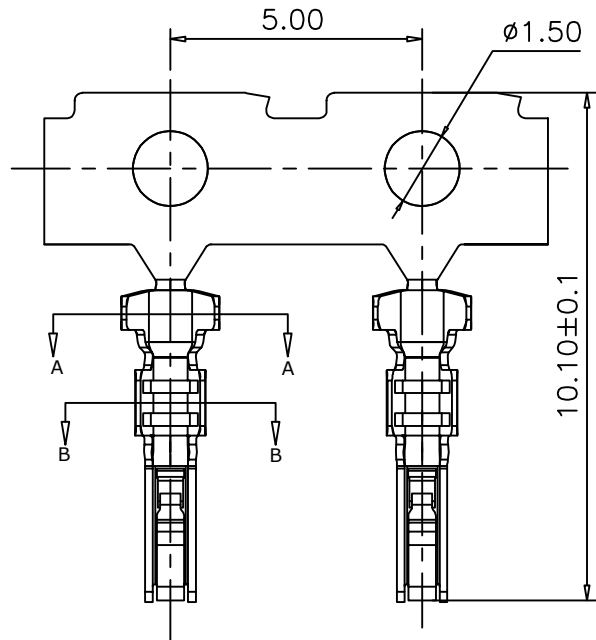

Specification:

- Current Rating: 2A AC/DC
- Voltage Rating: 125V AC/DC
- Insulation Resistance: $\geq 500M\Omega$
- Withstanding Voltage: 500VAC(1Min)
- Contact resistance: $\leq 20m\Omega$ (Max)
- After environmental testing: $\leq 40m\Omega$
- Operation Temperature: $-40^{\circ}C$ to $+105^{\circ}C$

Material:

- Wire Range: 24-30AWG
- Material: Phosphor Bronze, T=0.15mm
- Finish: Tin Plated

Ordering Information

SCT1506T P S 184

Material: P=Phosphor Bronze S=Contact Plated Tin Flash

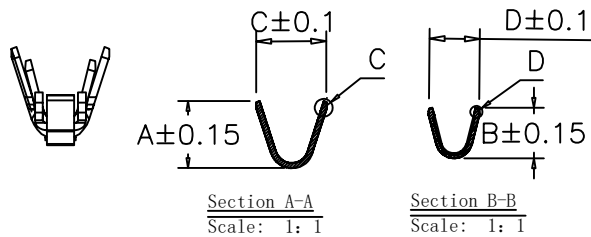

SCONDAR ELECTRONIC LIMITED
ENGINEER LIU APPROVED

Wire Range	A	B	C	D	MPQ
AWG26-30	1.4	0.65	1.65	1	10000PCS
AWG24-26	1.85	1.45	1.95	1.4	10000PCS

REV	DATE	MODIFICATION DESCRIPTION	CHANGE	APPROVE	OPERATION	DRAW	Peng	2019.08.16	SCALE	-	 SCONDAR ELECTRONIC LIMITED	
A0	2019.08.17	NEW			X.X	DESIGN			UNIT	mm		
					X.XX	CHECK	Lisa	2019.08.17	SIZE	A4		
					X.XXX	APPROVE	Allen	2019.08.18	SHEET	1/1		
					Angle				PROJ.	◆	PART NO.	SCT1506TPS184
					DIM				TITLE:			ZE1.50mm for SCT1506H Terminal